

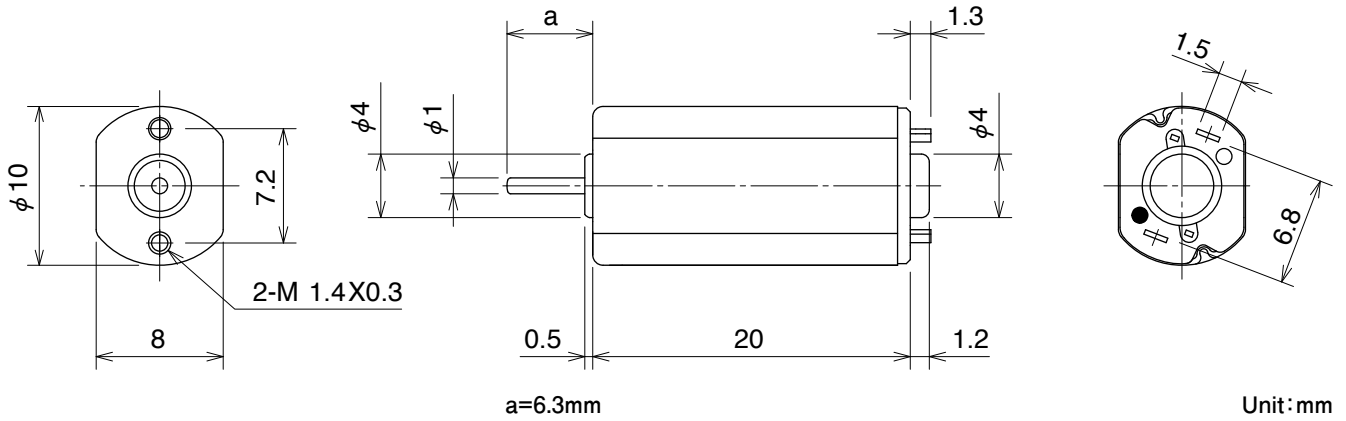

# PKN12

■ モータ外觀寸法 External Dimensions

Weight:5.3g



■ 参考特性 Reference Characteristics

型式 Model	電圧 Voltage		無負荷 No Load		定格負荷 Rated Load		定格負荷 Rated Load		起動トルク Starting Torque		起動電流 Starting Current
	駆動電圧 Operating	定格電圧 Rated	回転数 Speed	電流 Current	定格負荷 Rated Load		回転数 Speed	電流 Current	起動トルク Starting Torque		起動電流 Starting Current
	(V)	(V)	(min <sup>-1</sup> )	(mA)	(gf·cm)	(mN·m)	(min <sup>-1</sup> )	(mA)	(gf·cm)	(mN·m)	(mA)
PKN12EB105C	1 to 4	3.0	10023	25	2.0	0.2	7796	102	9.2	0.90	370

■ トルク特性 Torque Characteristics

