

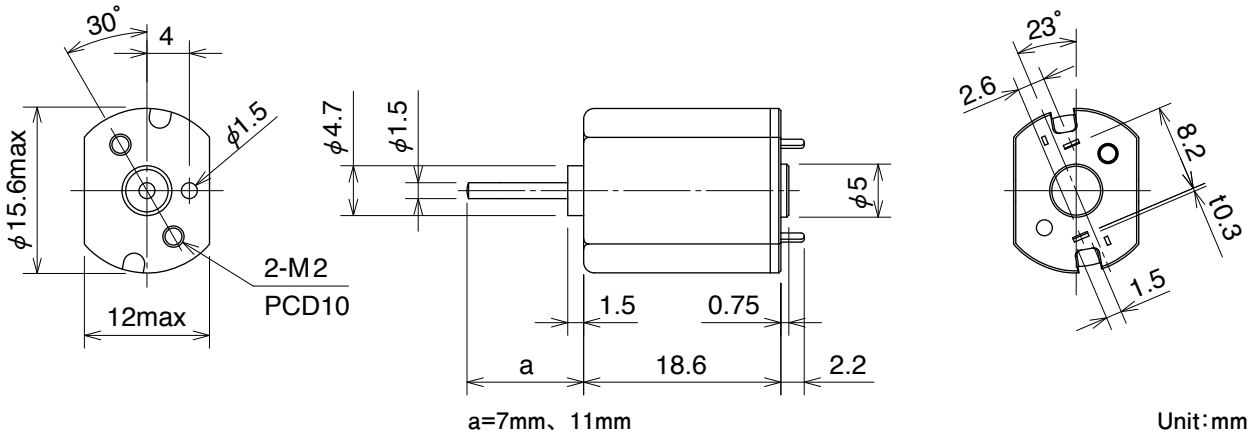

PPN7

■ モータ外觀寸法 External Dimensions

Weight:10g



■ 参考特性 Reference Characteristics

型式 Model	電圧 Voltage		無負荷 No Load		定格負荷 Rated Load		定格負荷 Rated Load		起動トルク Starting Torque		起動電流 Starting Current (mA)
	駆動電圧 Operating	定格電圧 Rated	回転数 Speed	電流 Current	定格負荷 Rated Load		回転数 Speed	電流 Current	起動トルク Starting Torque		
	(V)	(V)	(min ⁻¹)	(mA)	(gf·cm)	(mN·m)	(min ⁻¹)	(mA)	(gf·cm)	(mN·m)	
PPN7PA08B	2 to 7	2.5	3050	21	1.0	0.10	2600	35	6.9	0.7	118
PPN7PA09C	2 to 7	6.0	10520	47	5.0	0.49	8000	144	20.5	2.0	443
PPN7PA10C	2 to 7	6.0	12000	47	5.0	0.49	9500	157	23.6	2.3	567
PPN7PA11B	2 to 7	5.0	12000	57	5.0	0.49	9400	191	22.7	2.2	673
PPN7PA12C	2 to 7	5.0	14000	84	5	0.49	11600	235	29.5	2.9	957

■ トルク特性 Torque Characteristics

