

荷重変換器 型式/LOADCELL TYPE C2T1-300K~4T-A

仕様/SPECIFICATIONS

- 負荷特性/LOADING SPECIFICATIONS
 - 定格容量/Rated Capacity(R.C.) : 2.942 kN { 300 kgf }, 5.884 kN { 600 kgf }, 9.807 kN { 1 tf }, 19.61 kN { 2 tf }, 29.42 kN { 3 tf }, 39.23 kN { 4 tf }
 - 許容過負荷/Safe Overload : 150 %R.C.
 - 限界過負荷/Ultimate Overload : 200 %R.C.
 - 定格出力/Rated Output(R.O.) : 2.0 mV/V±0.002 mV/V
 - 非直線性/Non-linearity : 0.025 %R.O.
 - ヒステリシス/Hysteresis : 0.025 %R.O.
 - 繰り返し性/Repeatability : 0.025 %R.O.
 - クリープ/Creep : 0.03 %R.O./20 min
 - クリープ回復/Creep Recovery : 0.03 %R.O./20 min
- 電気特性/ELECTRICAL SPECIFICATIONS
 - 推奨印加電圧/Recommended Excitation : 12 V or less
 - 最大印加電圧/Maximum Excitation : 16 V
 - 零バランス/Zero Balance : ±0.02 mV/V
 - 入力抵抗/Input terminal Resistance : 420 Ω
 - 出力抵抗/Output terminal Resistance : 350 Ω ±3 Ω
 - 絶縁抵抗(ブリッジ-本体) /Insulation Resistance(bridge-body) : 2000 MΩ 以上(DC50 V) 2000 MΩ or more(DC50 V)
- 温度特性/TEMPERATURE PERFORMANCE
 - 温度補償範囲 /Compensated temperature range : -10 ℃ to 50 ℃
 - 許容温度範囲 /Safe temperature range : -20 ℃ to 70 ℃
 - 零点の温度影響 /Temperature effect on zero balance : 0.05 %R.O./10 ℃
 - 出力の温度影響 /Temperature effect on output : 0.02 %LOAD/10 ℃
- その他/OTHERS
 - ケーブル/Cable : φ6.3 4芯シールド付 6m直結 先端Y型圧着端子付 φ6.3 4-core shielded cable 6m Cable end Y-shape terminal
 - 保護等級/Class of protection : IP64
 - 起歪体の材質/Material : アルミニウム合金/Aluminum alloy
 - 疲労寿命/Fatigue Life : 定格容量で10⁶回/10⁶ times with rated load
 - 表面処理/Finish : エポキシ樹脂塗装(黒)/Epoxy resin paint(Black)
 - RoHS : 適合/Compliant
 - 別売品/Selling separately : 球面ボール受け金具/Metal fittings(TB-**A)
- 配線図/CIRCUIT DIAGRAM

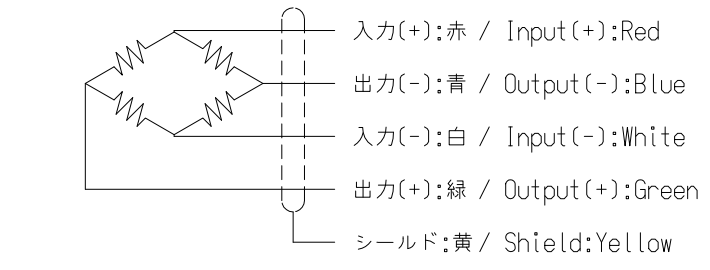
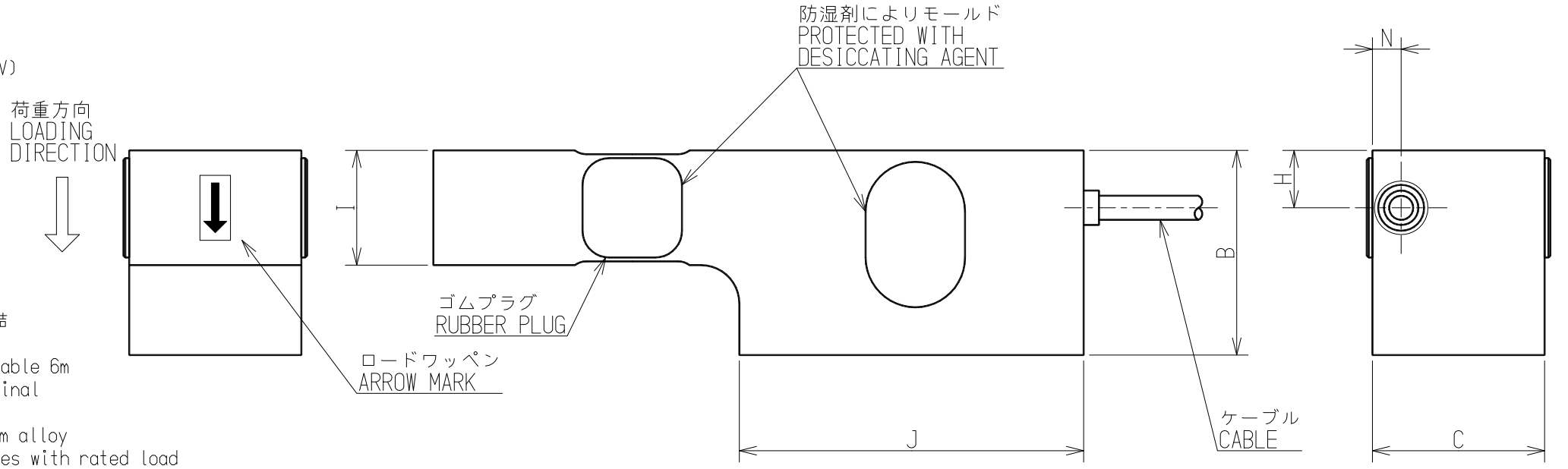
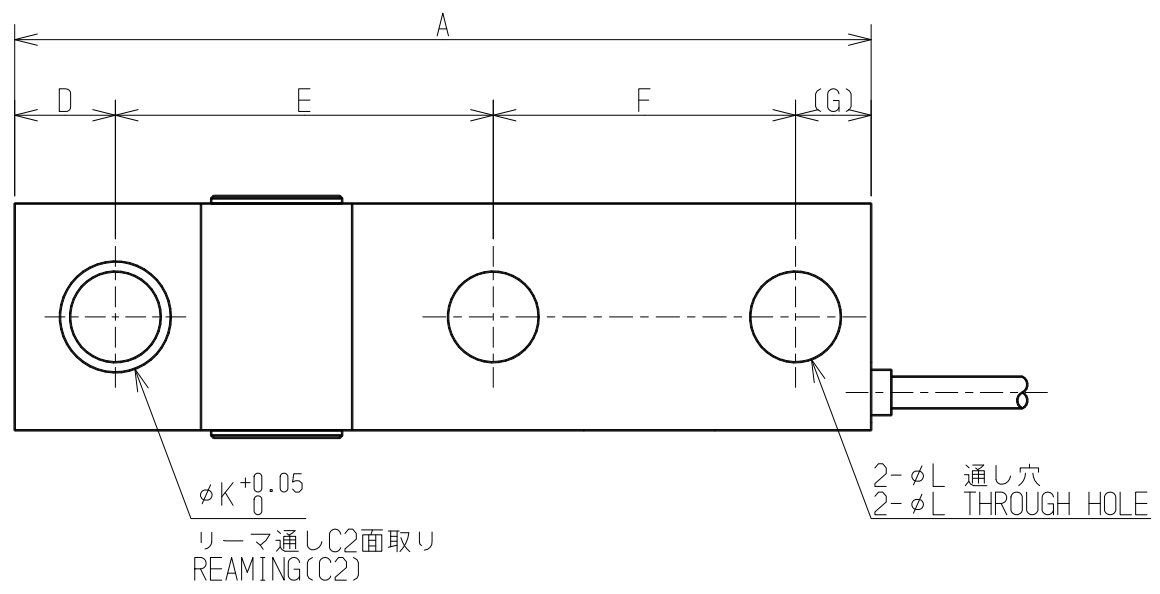

<<付属品/Accessories>>
試験成績表/Calibration Certificate 1

<<外形寸法表/Outside>>

型式 TYPE	定格容量 Rated capacity	A	B	C	D	E	F	G	H	I	J	φK	φL	N	定格変位量(参考値) Rated Displacement (Reference)	固有振動数(Hz) Natural Frequency (Hz)	質量(約kg) Weight(approx.kg)
C2T1-300K-A	2.942 kN{300 kgf}	170	53.5	45	20	75	60	15	15	30	90	18	18	7.5	0.25	3700	1.1
C2T1-600K-A	5.884 kN{600 kgf}	170	53.5	45	20	75	60	15	20	40	90	18	18	7.5	0.25	5000	1.1
C2T1-1T-A	9.807 kN{1 tf}	170	53.5	50	20	75	60	15	24	48	90	18	18	10	0.28	5500	1.3
C2T1-2T-A	19.61 kN{2 tf}	170	53.5	50	20	75	60	15	25.5	51	90	18	18	10	0.32	6800	1.3
C2T1-3T-A	29.42 kN{3 tf}	205	77.5	58	20	115	50	20	36	72	95	24	22	10	0.40	5500	2.4
C2T1-4T-A	39.23 kN{4 tf}	205	77.5	58	20	115	50	20	37	74	95	24	22	10	0.40	6700	2.4

			ミネベア株式会社 Minebea Co.,Ltd. センシングデバイス事業部 Sensing Device Business Unit		単位 UNIT mm 尺度 SCALE Free	材質 MATERIAL - 表面粗さ SURF.ROUGH. - 熱処理 HEAT TREAT. - 表面処理 FINISH -	作成日 DATE 2016.05.20 品名 DESCRIPTION 外觀仕様図/OUTLINE 型式 MODEL NAME C2T1-A 図番 DRAWING NO. KT53151-2 改訂 REV. A
一般公差	DIMENSION L	TOL					
	<L≤4	±0.1					
	4<L≤16	±0.2					
	16<L≤63	±0.3					
	63<L≤250	±0.5					
	250<L≤1000	±0.8					
	角度 DEG	±0.5					